



Original instructions
OPERATING INSTRUCTIONS 2-20DT
VERSION 3.3





Inspection comments

Inspection before initial operation on: _____

By: _____

Date of initial operation: _____

Serial number & Year of manufacture: _____

Recurring inspections / maintenance log

Date / Hour counter	Findings	Repairs / Cleaning	Test on	By*

*Competent person

Table of contents

Inspection comments	2
1. Introduction	4
2. Machine description	4
3. Safety	5
3.1 Work area safety	5
3.2 Electrical safety	5
3.3 Personal safety	6
3.4 Machine safety	6
3.5 Shot / steel blasting safety	7
3.6 Dust collector safety	7
3.7 Maintenance safety	7
3.8 Transport safety	7
3.9 Signs on the machine	9
4. Before operation	10
4.1 Checkpoints of power supply	10
4.2 Checkpoints of the machine	10
4.3 Drive control	10
4.4 Control box	11
4.5 Transport	12
4.6 Manual moving of the machine	12
4.7 Driving without connected drive motor	12
4.8 Connecting the drive motor to the traction wheel	13
4.9 Driving with connected drive motor	14
4.10 Blast wheel	14
4.11 The abrasive valve	14
4.12 Separator	14
4.13 Abrasive sealing	15
4.14 Changing the transmission ratio (option)	16
5. Operation	17
5.1 Before switch on	17
5.2 Checking & Correcting the turning direction	17
5.3 Switching the machine on	17
5.4 Operation	18
5.5 Switching the machine off	18
5.6 The blast pattern	19
5.7 Adjusting the blast pattern	19
6. Maintenance	20
6.1 Changing the tune-up kit	22
6.2 Changing the liners	23
6.3 The V-belt	26
6.4 V-belt mounting	26
6.5 V-belt tension	26
6.6 The chain drive	27
7. Selection of abrasive	28
8. Troubleshooting	29
9. Technical data	31
Contact	

1. Introduction

Before use, operators must be provided with information, instruction and training for the use of the machine and the substances for which it is to be used, including the safe method of removal and disposal of the material collected. All persons who are working with or maintaining this machine must read the manual carefully and understand it fully. In case you sell the unit, hand it on to the next owner.

Keep this manual always with the machine, to enable it to be referred to at any time.

Any other work not covered by this operating manual must not be carried out.

This machine is designed for industrial use by professionals. Only authorized and trained personnel may operate this machine. This machine is not intended for use by persons (including children) with reduced physical, sensory or mental capabilities, or lack of experience and knowledge. **Blastrac BV** offers a course on the use of the machine in order to make the operating and maintenance personnel familiar with all elements of the machine.

2. Machine description

The **Blastrac** blast cleaning machine 2-20DT is a downward blasting machine with a closed abrasive circuit exclusively designed for the pre-treatment of dry, frost free horizontal surfaces. The bouncing impact of metallic abrasive onto the surface to be treated thoroughly removes surface contaminants, coats of paint, sealants and thin coatings. The intended use of this machine is blast cleaning of the following surfaces: Steel, concrete, stone and asphalt. The machine may not be used for other purposes. The manufacturer will not be liable for damage resulting from incorrect usage, in these cases the user assumes all risks.

A suitable filter unit must be connected to the machine in order to separate the dust from the abrasive. A specially designed Blastrac dust collection system ensures dust-free operation of the machine and clean air at the workspace.

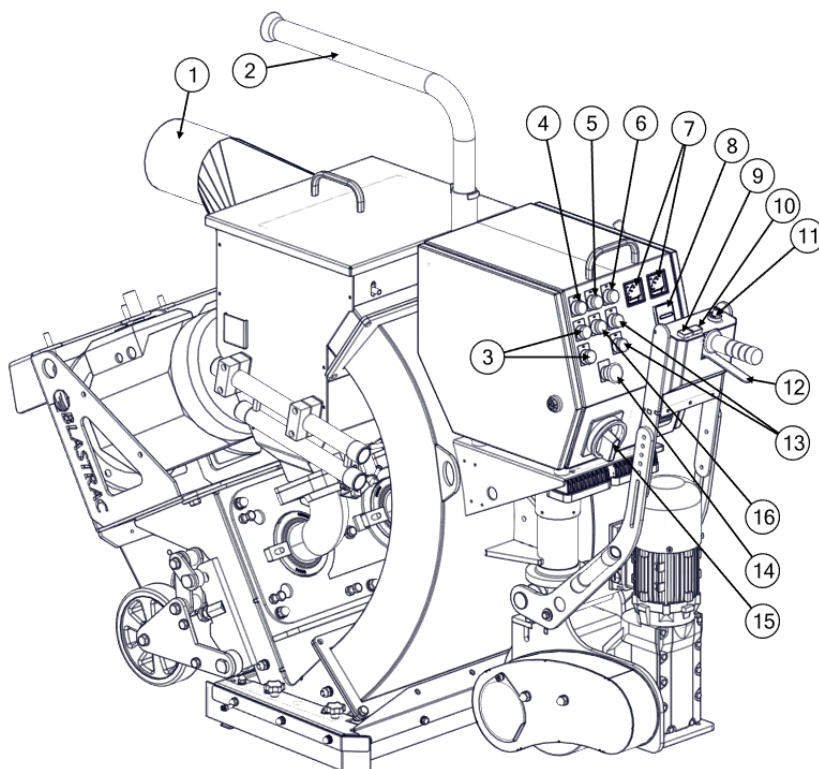

1	Connection pipe for dusthose
2	Cable guide
3	Drive control ON and OFF
4	Control lamp CONTROL VOLTAGE ON
5	Control lamp FAULT
6	Control lamp BLASTMOTORS ON
7	Ammeters left & right blast motor
8	Hour counter
9	Overdrive
10	Move forwards
11	Speed control
12	Travel switch
13	Blast motors ON and OFF
14	Emergency shutdown
15	Main power switch
16	Worklights ON / OFF



3. General Safety Rules



Warning!

Read all safety warnings and all instructions. Failure to follow the warnings and instructions may result in electric shock, fire, explosions and / or serious injuries.

Only authorized and trained personnel may operate this machine. This machine is not intended for use by persons (including children) with reduced physical, sensory or mental capabilities, or lack of experience and knowledge.

It is the responsibility of the user to analyse the surface to be treated. The surface may not contain any substances which could pose a fire-, explosion- or health risk when treated. The user should make a risk assessment on the basis of the information obtained about the surface to be treated and take proper precautions for the work to be performed.

In case of any inappropriate usage, improper operation or repair, the producer shall be exempt from liability.

3.1 Work area safety

- a) Do not use the machine in rain, damp or wet locations.
- b) Avoid dangerous environments: do not work in the presence of explosive atmospheres, in the presence of flammable liquids, gases or dust. Remove materials or debris that may be ignited by sparks.
- c) In some cases sparks could be created by the blast cleaning process.**
- d) The surface to be treated must be clean, make sure to remove all stones, screws etc..**
Any stones, screws, bolts, pieces of wire etc. could cause serious damage to the machine if it gets inside the machine!
- e) Make sure there is enough ambient light on the work area. Cluttered or dark areas invite accidents.
- f) Keep children and bystanders away while operating the machine. They are likely not to foresee the potential dangers of the machine. Distractions could cause you to lose control of the machine.
- g) Persons who are not operating the machine must not be permitted to stay in the surrounding area of at least 5 meter from the machine.
- h) Never use the machine when the surface is not clear and if there is a risk of stumbling or tripping.
- i) Remove electrical cables and dust hose(s) from the surface to be treated.
- j) Make sure that there are no cables or hoses in the driving direction of the machine.
- k) Make sure that there is nothing standing or situated on the surface to be treated.
- l) Make sure the machine can travel over all inequalities on the surface, small inequalities like weld seams or (floor) joints are no barriers for the machine.
- m) Never operate the machine when workplace is wet. Never stay in the rain with the machine.**
- n) Check if there are any obstacles that can snag the cables when the machine is moving.
- o) Remove all objects from the surface that can damage the machine. Remove reinforcing steel or other objects protruding from the surface in order to prevent damage to the machine.
- p) Warning! Make sure that the surface to be treated does not contain dangerous materials such as:**
 - combustible or explosive dusts or substances.
 - carcinogenic or pathogenic substances.
- q) It is necessary to provide for an adequate air change rate L in the room if the exhaust air is returned to the room. Comply with the National regulations.
- r) Secure the work area around the machine in public areas providing an adequate safety distance from the machine. Use a red and white safety chain and danger sign to enclose the work area.

3.2 Electrical safety

- a) Use only extension cables for extending the main cable that are sized and marked in accordance with the overall power consumption of the machine. Do not use damaged extension cables.
- b) Electrical cables must be rolled entirely off of the reels.
- c) Any damage to the electric cables and/or electrical components is not permitted.
- d) If the power supply cable is damaged, it must be replaced immediately. Only use original Blastrac parts.
- e) The voltage on the identification plate must comply with the power supply.
- f) Use an electrical power supply connection with earth connection and earth leakage circuit breaker.
- g) The circuit breaker of the power supply must have a "D" characteristic. Circuit breakers with a "C" or "B" characteristic can give problems when switching the machine on.



- h) **Keep the machine original; The machine is always equipped with an earthed connection, do not change this** and always use earthed cables with an earthed plug.
- i) Inspect and test the electrical components regularly. The electrical components have to satisfy with the requirements set out in the harmonised norm EN60204-1.
- j) Always call a skilled electrician or your distributor when you have questions about the safety of the electrical components.
- k) Work on electrical equipment or operating materials may only be undertaken by a skilled electrician or by trained persons under the guidance and supervision of a skilled electrician as well as in accordance with the electrical engineering regulations.
- l) Always use tools that are insulated against voltages.
- m) Do not abuse the cables. Never use the cables for carrying, pulling or unplugging the machine. Keep cables away from heat, oil, sharp edges or moving parts. Damaged or entangled cables increase the risk of electric shock. Do not fold the cable or clamp it.
- n) Don't pull out the power supply cable out by the wire, but by the connector.
- o) Be careful with water on the treated surface. Electrical cables must not come into contact with water.
- p) The main power switch on the machine must be in the "Off" position before connecting to the power supply.
- q) During a long standstill of the machine, pull out the main plug.
- r) If the machine is to be operated using power from a generator, the generator must be operated in accordance with the current legal regulations and directives in force. (this applies to the protective earth conductor in particular) in order to ensure that all safety devices are functioning and to eliminate possible damage to electrical components.

3.3 Personal safety

- a) **Always wear Personal Protective Equipment while working with the machine.**
 - Dust mask class FFP2 or higher
 - Ear protection
 - Safety glasses with lateral protection
 - Protecting gloves
 - Safety shoes
- b) Dress properly. Do not wear loose clothing or jewellery. Keep your hair, clothing and gloves away from moving parts.
- c) Personnel must tie back long hair and not wear loose clothing or jewellery including rings.
- d) Stay alert, watch what you are doing and use common sense when operating the machine.
- e) Always seek professional medical attention immediately in case of injury.
- f) All persons surrounding the machine should wear Personal Protective Equipment.

3.4 Machine safety general

- a) Safety functions and operating functions must work correct.
- b) No loose bolts and nuts permitted.
- c) Never operate machine without the guards and/or safety devices in place.
- d) Never change anything on the safety devices on the machine!
- e) Do not use the machine when it is damaged.
- f) Do not **open** or **remove protective guards** while driving gears are running.
- g) The machine, specially the handle grips must be dry and free of fats/oils.
- h) If the length of the brushes is, due to wear, less than 5mm or they are extremely deformed, the brushes have to be replaced. Check the Service Manual for the order numbers.
- i) All repair work has to be done by qualified Blastrac personnel, this guarantees a safe and reliable machine.
- j) Always use original Blastrac spare parts and abrasive. This will ensure the best performance. Only original parts meet the factory specifications and quality. Otherwise Blastrac BV cannot guarantee the safety of the machine. The part numbers can be found in the Service Manual.
- k) Check the rotating direction of the motors before operation. The correct direction is given with an arrow on the housing of the motors.
- l) If safety-critical changes occur to the machine or its working method, the machine must be shut down immediately! The cause of the fault must be established, and rectified.
- m) In the event of operational malfunctions the machine must be shut down immediately and secured!
- n) **Never use the machine without a suitable (Blastrac) dust collector!**



3.5 Shot/steelblasting safety

- a) Never lift the blast head during blasting! This could cause serious injury to yourself and others around you!
- b) **Abrasive can escape from the sides of the blast head at high speed!** Wear safety glasses with lateral protection and close-fitting protective clothing.
- c) Be very careful when inserting the quick release pin into the traction wheel.
- d) Check the following parts daily for damage and wear to avoid unnecessary long and costly standstill on the workplace; blastwheels, feedspouts, liners, magnet- and brush sealing; Replace the parts when you can see obvious signs of wear and tear. Wear grooves are acceptable until 75% of blade thickness has been worn away.
- e) Check the parts of the separator on wear and defects. Remove foreign bodies and dust deposits to prevent clogging of the separator.
- f) The cover of the separator and separator tray must be closed to keep the vacuum in the machine.
- g) **The machine will heat up during blasting!** Don't risk getting burned, always wear gloves and only touch the handle grip(s).
- h) Check the level of abrasive in the storage hopper before work starts. Refill if necessary.
- i) Remove the abrasive from the abrasive storage hopper before storage.
- j) **In some cases sparks could be created by shot / steelblasting.**

3.6 Dustcollector safety

- a) Always use a Blastrac dust collector to ensure a dust-free operation of the machine and clean air at the workspace. Also the airflow helps to cool the machine and prevents overheating.
- b) Read the operating instructions of the dust collector before using it.
- c) The dust container/bag of the dustcollector must be emptied regularly. Comply with the local waste treatment regulations considering the removed material.
- d) The dust hose must be connected properly with a hose clamp and industrial tape.
- e) The dust hose must be undamaged and free of obstructions.
- f) Always switch on the dust collector first!

3.7 Maintenance safety

- a) Pull out the main plug and place it in sight, before starting inspections and repairing on the machine. The main switch can be locked in the "OFF" position by using a padlock and placing it through the main switch.
- b) Wait for standstill of all drives before any inspections, adjustments and/or maintenance work is started.
- c) Block machine in stable position before doing any maintenance work.
- d) Failures due to inadequate or incorrect maintenance may generate very **high repair costs** and long standstill periods of the machine. **Regular** maintenance therefore is imperative.
- e) Operational safety and service life of the machine depends, among other things, on proper maintenance.
- f) Prevent premature wear by keeping the machine as dust free as possible. Clean the machine for this reason regularly with a dust collector and non-aggressive materials. Never use a high pressure water cleaner to clean the machine.
- g) Do not use any **aggressive** cleaning materials!
- h) Use lint-free **cleaning cloths!**
- i) It is advisable to stock all spare parts or wear parts that cannot be supplied quickly. As a rule, production standstill periods are more expensive than the cost for the corresponding spare part.
- j) The suitable precautions include decontamination before disassembling the machine, adequate filtered ventilation of the exhaust air from the room in which it is disassembled, cleaning of the maintenance area and suitable personal protection equipment.

3.8 Transport safety

- a) Be aware of your surroundings and machine operating level. Do not side hill, do not run on steep incline, this could cause machine to tip over.
- b) The net weight of the 2-20DT is 630 kg. Use a crane or lift when transporting the machine, use the lifting eyes / lugs of the machine.
- c) Before every use check the lifting eyes/lugs and welds for: deformation, damages, cracks, corrosion and wear.
- d) **Pay attention that the drive unit does not turn away during lifting of the machine.**



Hold on to the steering handle until the machine is off the ground.

- e) When lifting the machine from the ground, always use the lowest lifting speed. The cables must first be tensioned at this speed; they must not be slack when the machine is lifted from the ground.
- f) During hoisting make sure to be at a safe distance from the machine with the most optimal view on the machine and working environment.
- g) Never stand directly below the machine.
- h) When transporting the machine do so in such a manner that damage due to the effects of the use of force or incorrect loading and unloading is avoided.
- i) The lifting eyes can also be used to fasten the machine on a pallet or during transport.
- j) Always drive backwards when driving up to a ramp or grade, and forwards when driving off the ramp.
- k) Chock wheels for transport and keep control handle in neutral position.
- l) Don't leave the machine unsecured on jobsites.
- m) Park the machine always on a flat horizontal and levelled surface.
- n) Remove the abrasive from the machine before transport.
- o) Make sure the electrical cable and dust hose are disconnected before transport.
- p) Store the cleaned and dry machine in a humid free room. Protect the electrical motor from moisture, heat dust and shocks.
- q) Never use the machine for lifting persons or items.

Only lift the machine as shown in the picture below.

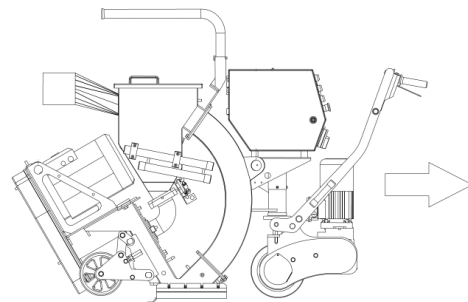
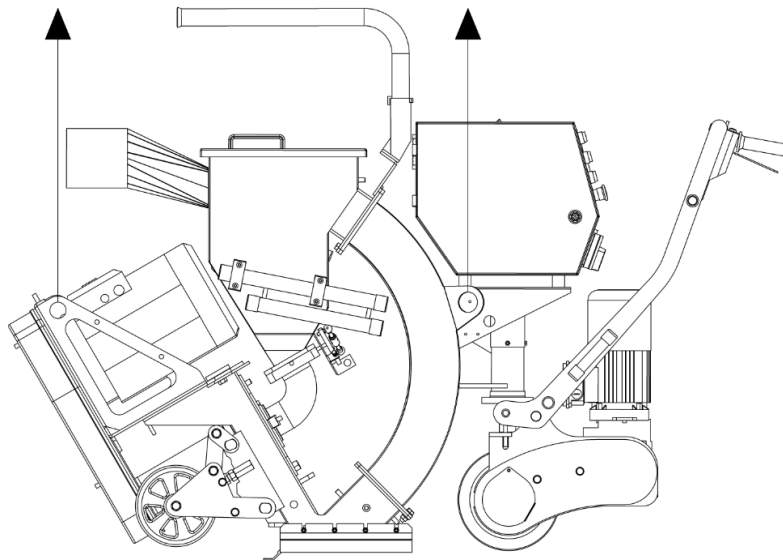

Working direction of the machine.



3.9 Signs on the machine

The following stickers are placed on the machine. Meanings of these symbols are:



! Danger Hazardous voltage in motor even when solid state controller is OFF. Disconnect main power before servicing motor, controller or associated wiring.



DANGER Rotating parts inside. Keep hands clear. Lock-out / shut down before servicing.



Lifting point.



Wear a dust mask class FFP3 or higher.



Hearing protection is obliged.



Safety glasses with lateral protection are obliged.



CE-mark on this machine.



Wear protecting gloves.



Safety shoes obliged.



Consult the manual before operating the machine.

Type plate:

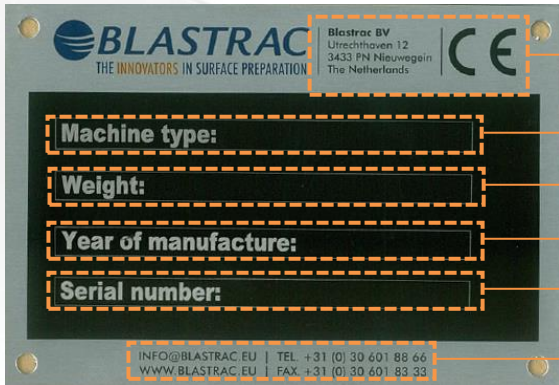

Name, address and CE mark.

The machine type.

The net weight of the machine in kilogram.

The year of manufacture.

The serial number of the machine.

Email address, Website, Telephone & fax number.

EU Declaration of Conformity:



4. Before operation

Before using the machine it is of great importance to inspect the machine.
It is not permitted to use the machine if the machine safety is not according the checkpoints below.

4.1 Checkpoints power supply

- Use only extension cables for extending the main cable that are sized and marked in accordance with the overall power consumption of the machine.
- Electrical cables must be fully unwind of their reels.
- No damage is permitted for electrical cables.
- Use an electrical power supply connection with earth connecting.
- The main switch of the machine should be put to 'Off' before connecting to the power supply.
- Make sure the power supply is in accordance with the machine specifications.
- The circuit breaker of the power supply must have a 'D' characteristic. Circuit breakers with a 'C' or 'B' characteristic can give problems when switching the machine on.
- If the machine is to be operated using power from a generator, the generator must be operated in accordance with the current legal regulations and directives in force. (this applies to the protective earth conductor in particular) in order to ensure that all safety devices are functioning and to eliminate possible damage to electrical components.

4.2 Checkpoints of machine

- Safety functions and operating functions must work correct.
- Check all screws and other fasteners for tightness. No loose bolts and/or nuts are permitted.
- Check the electrical components, cables and connections for wear and/or damages.
- Dust hose connection must be reliable: use hose clamps and industrial tape.
- Dust hoses must be undamaged and free of obstructions
- Check the following parts for damage and wear: blastwheels, feedspouts, liners, magnet- and brush sealing. Replace the parts when you can see obvious signs of wear.
Wear grooves are acceptable until 75% of blade thickness has been worn away.
- Check de parts of the separator on wear and defects. Remove foreign bodies and dust deposits.

4.3 Drive control

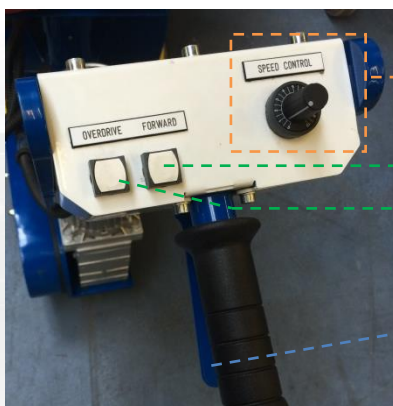

Dial for setting the drive speed.

Buttons for:
Forward driving (Hold to run)
Overdrive (Hold to run)

Drive handle (Hold to run) to activate the drive motor. When the lever is released the drive motor switches off.

4.4 Control box

The control box is equipped with all control elements and instruments for monitoring and controlling the machine.

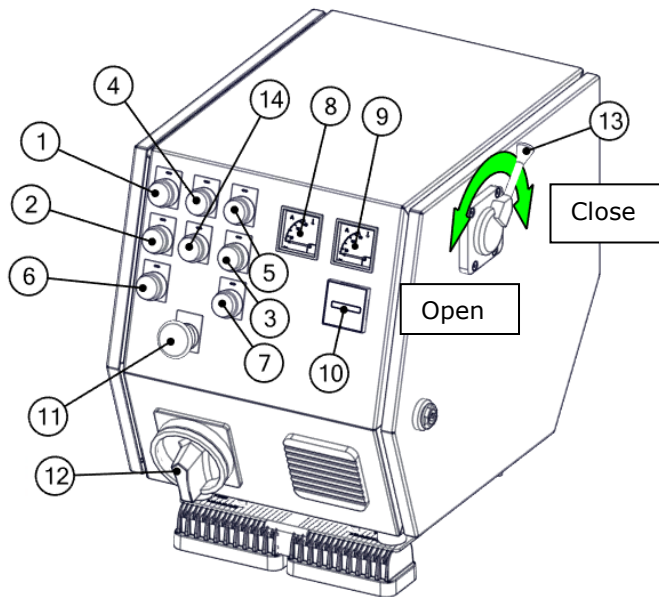

1	Control lamp "Control"
2	Push button "Control ON"
3	Push button "Blast wheel ON"
4	Control lamp Motor protection
5	Control lamp "Blast wheel"
6	Push button "Control OFF"
7	Push button "Blast wheel OFF"
8	Ammeter blast wheel
9	Ammeter blast wheel
10	Hour counter
11	Emergency shutdown button
12	Main power switch
13	Abrasive control lever
14	Worklights ON/OFF

1 + 2 + 6 Control lamp, push buttons "Control ON/OFF"

Pressing the push button "Control ON" switches the control on and makes the control lamp light up. Pressing the push button "Control OFF" switches the control off.

4 Control lamp motor protection

This red lamp lights up when the complete electronics has been switched off by overload of one of the motors.

5 + 3 + 7 Control lamp, push buttons "Blast wheel ON/OFF"

Pressing the push button "Blast wheel ON" switches the blastwheel motor on and makes the white control lamp light up. Pressing the push button "Blast wheel OFF" cuts off the power supply immediately.

8 + 9 Ammeters

These meters indicate the power consumption of the blastmotors in ampere. The ammeters show the blast cleaning load onto the surface. When switching on the motors the current value peaks shortly. The no-load current is approximately (2x) 7A. The maximum operating current is (2x) 20A.

9 Hour counter

Shows the number of actual working hours performed by the blastwheel. Useful for maintaining a proper maintenance schedule.

11 Emergency shutdown button

Red mushroom-shaped emergency shutdown push button, this button cuts off all power to the machine. Turn to unlock. After use of the emergency button, all functions have to be re-started manually.

12 Main power switch

The main power switch is located on the control box. It has to be switched OFF when connecting the machine to the power supply. It has to be switched ON before operating the machine. The main power switch can be locked in the "OFF" position by using a padlock and placing it through the main switch.

13 Abrasive control lever

This lever is located on the right hand side of the control box. It regulates both magnetic valves to control the flow of abrasive towards the blast wheels. The valves are hand-operated, pull the lever towards you to open. Push the lever towards the machine to close.

14 Worklights

Button for turning the LED worklights ON or OFF.



4.5 Transport

When transporting the machine from a vehicle to the work area you can put the machine in its transport position by using the lever of the lifting mechanism.

To do this, place the lever onto the bracket(2), as shown in the picture. Now press the lever down until the pivot bracket noticeably locks over its point of rotation.

To place the brackets in operating position, place the lever und move it slowly upward (1), until the pivot bracket sits close at the height adjustment screw.

WARNING!!

Always put both wheels back to the operating position before turning on the blastwheel motor!
Never start blast cleaning when the wheels are in transport mode!

Be careful! Make sure nobodies feet get under the wheels. Wear appropriate safety shoes when you drive the machine to or from the work area.

Make sure that no vehicles, such as forklift trucks and other equipment run over the electric cable and the dust hose.

WARNING!!

Always make sure the blastwheel has come to a complete standstill before moving around the machine in transport mode!

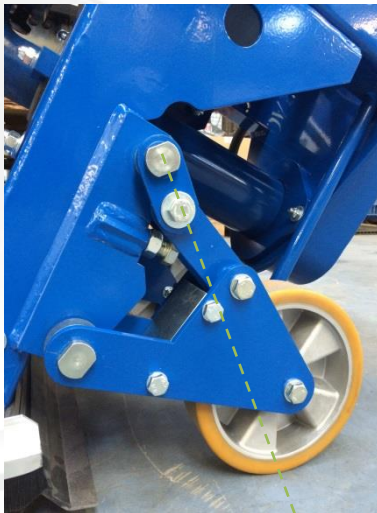

Transport position

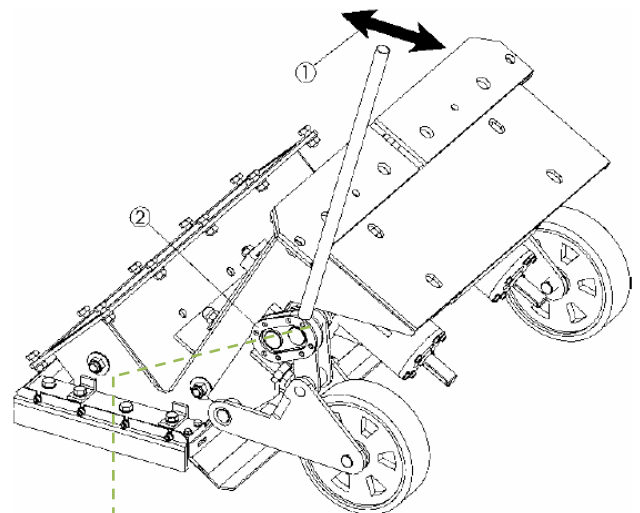

Operating position

4.6 Manual moving of the machine

Driving without connected drive motor

When the traction wheel is not connected to the drive motor you can tilt the complete drive unit downwards, by pressing down on the handgrip of the drive unit. This will lift the blasthouse off the ground and makes it easier to move the machine around.

WARNING! Never lift blasthouse of the ground while blasting! This could cause serious injury to yourself and others around you!



4.7 Connecting the drive motor to the traction wheel

1		<p>Danger of crushing!</p> <p>Use common sense, do not get distracted during the activities.</p>	5		<p>Insert the quick release pin inside the hole.</p>
2		<p>Make sure the magnetic valves are CLOSED.</p> <p>Make sure the Blast motors are OFF.</p>	6		<p>!WARNING! Use only 1 finger to press the button of the quick release pin, and keep applying pressure.</p>
3		<p>Set the drive speed knob to the lowest possible setting, approximately 0,5.</p>	7		<p>Use your other hand to operate the drive-motor handle (10).</p>
4		<p>Open the wheel guard.</p>	8		<p>When the drive-motor and wheel are aligned, the quick release pin will lock into place.</p> <p>Close wheel guard.</p>

4.8 Driving with connected drive motor

Set the driving speed at the desired speed using the speed control knob. Place 1 hand on the handle grip and squeeze the switch lever, this will move the machine towards you, this is the normal working direction for blasting. Release the switch lever to stop. The driving speed can be adjusted while driving by turning the speed control knob.

The OVERDRIVE-button makes it possible to drive at maximum speed without having to adjust the speed control knob. To do so, press and hold the OVERDRIVE-button while driving. **WARNING!** Mind your surroundings at maximum speed!

The FORWARD-button is used to drive forward, press and hold the button to do so. **WARNING!** Do not drive forward while blasting! This function is only used for maneuvering without blasting. Make sure the dust hose and electrical cable are out the way when driving forward.





4.9 Blast wheels

The heart of the blast cleaning machine are the blast wheels which throw the abrasive onto the surface to be cleaned by using centrifugal force. The blast wheels are placed in a protective housing lined with replaceable wear plates. The blast wheels are driven by electric motors.

Around the centre of the blastwheel there is the impeller, feeding dosed quantities of abrasive onto the blades of the turning blast wheel. On top of this is the control cage which, once it is carefully set, regulates the flow of abrasive.

14	Wheel hubs
10	Blast wheels
2	Blast wheel cover plate
11	Control cage shims
15	Control cages
16	Control cage clamps

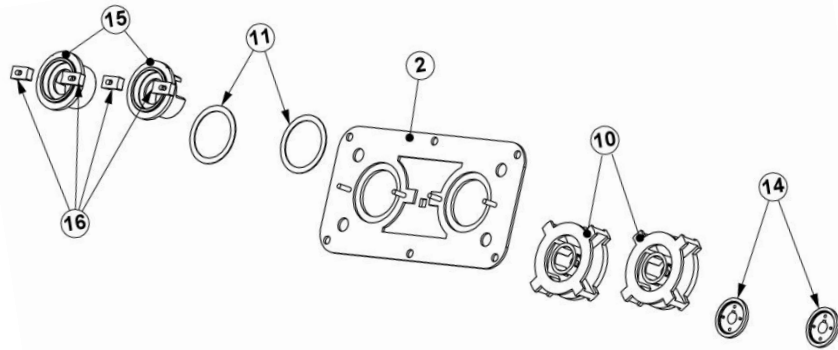

4.10 The abrasive valve

Between the abrasive storage hopper and the feed spouts there are valves incorporating permanent magnets in order to control the abrasive flow towards the blastwheels. Any change in the opening of the magnetic valve causes the amount of abrasive fed to the blastwheel to change. The change in the abrasive fed can be read from the ammeters. The valves are hand-operated by the **abrasive control lever**. This lever is located on the side of the control box and can be adjusted so that any quantity of abrasive can be fed to the blastwheels. Optimum blast cleaning power is reached when the ammeters indicate the operating current. It is not permitted to blast with a higher current value. The control lever operates both magnetic valves simultaneously.

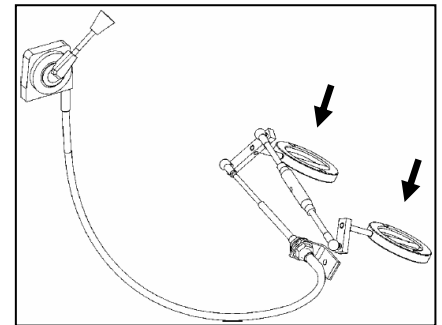

4.11 Separator

The abrasive separator is mounted to the end of the rebound plenum. It separates the abrasive from contaminants and feeds the cleaned abrasive back to the abrasive circuit. A wire mesh is fitted to prevent any large contaminants from getting into the blast wheels. In order to clean the wire mesh drawer, the separator cover can be removed or the wire mesh drawer can be removed from the side. Check and empty the drawer before and after each operation.

During operation U should check the separator tray every 3 hours for foreign matter and large contaminants.

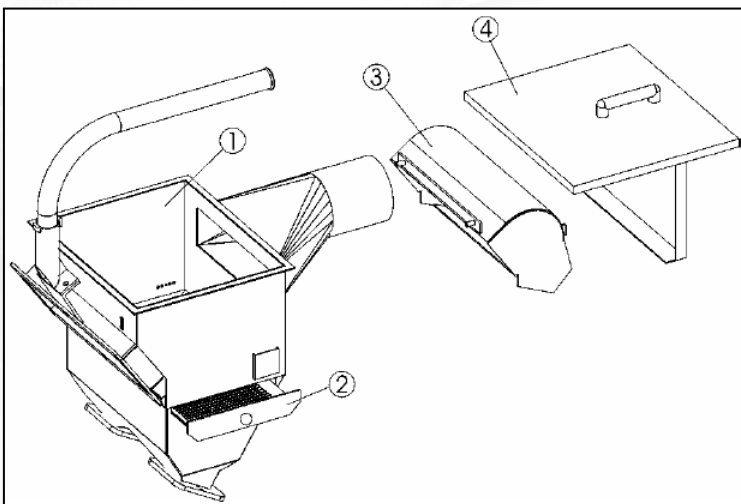

1	Separator
2	Separator drawer (wire mesh)
3	Deflector
4	Separator cover



4.12 Abrasive sealing

Magnetic seals are fitted to the front and the sides of the blast housing outlet and are surrounded by brush seals. At the rear there is a seal sliding over the floor. The seals are employed to seal the blasting area in a way to avoid leakage of any abrasive.

The correct height adjustment of the magnetic seals (8–10 mm) is very important for optimum functionality of the machine.

The adjustment is done using the 4 setting screws (one each at the rear wheels and one at the front drive wheel bracket below the control box).

The height of the brush seals should be maximum 1 mm above the surface. Adjustment is effected through slotted holes. If the length of the brushes is, due to wear, less than 5mm or they are extremely deformed, the brushes have to be replaced!

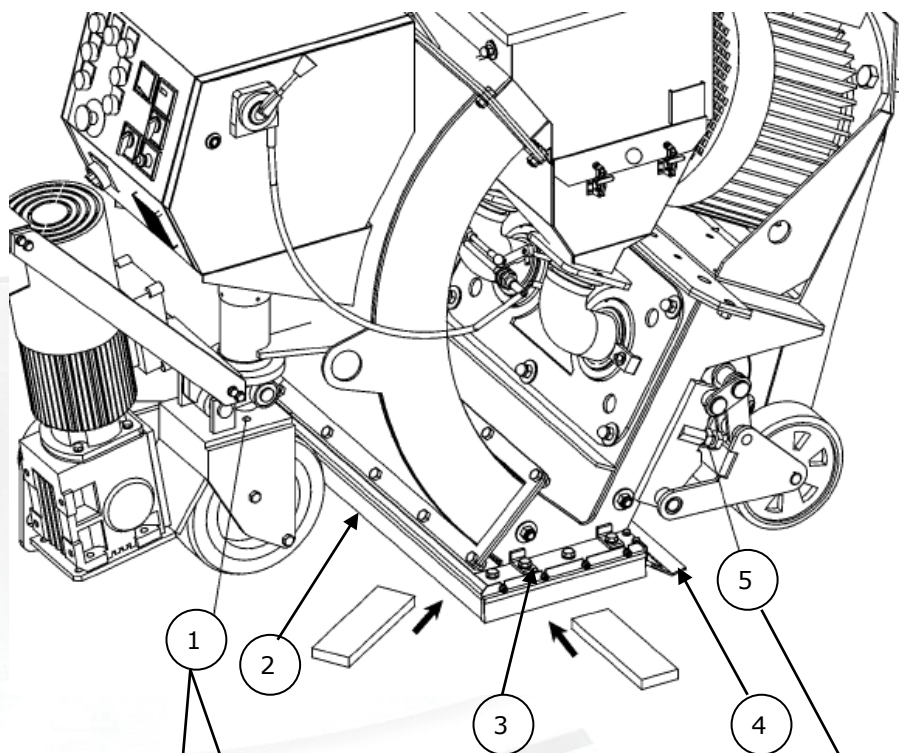

1	Setting screws drive wheel (quantity: 2)
2	Brush seal
3	Side magnet
4	Rear seal
5	Setting screws rear wheel (quantity: 2) One on each rear wheel.

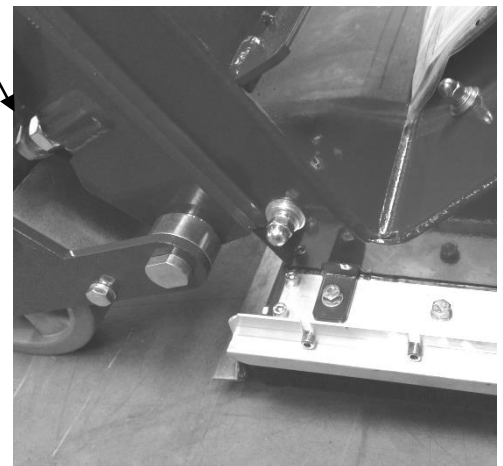
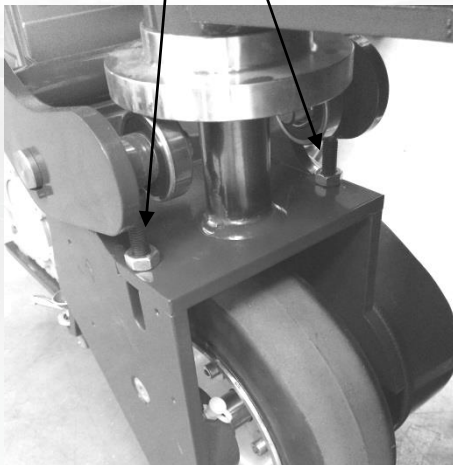



4.13 Changing the transmission ratio (only for machines with an adjustable drive option)

This option allows you to alter the machine for a 50Hz or 60Hz power supply with minimum effort.

- Remove the pulley guard.
- Loosen the 4 bolts of the blast motor (do not remove them).
- Loosen the 2 tension nuts. The belts will be untensioned now.
- For the 50Hz configuration place the 2 V-belts into the smallest two grooves of the bottom pulley. (see figure below)
- For the 60Hz configuration place the 2 V-belts into the biggest two grooves of the bottom pulley. (see figure below)
- Check the pulley alignment and correct if necessary.
- Tension the V-belts by tightening the tension nuts. For an accurate result a tension gauge needed.

2 ways to tension the v-belts:

- *Measuring belt tension by deflection:* Put the tension gauge in the middle of the span length of the V-belt. The deflection must be 3.5mm by a deflection force of 11N for a new belt. For used belts the deflection must be 3.5mm by a deflection force of 9N.
- *Measuring belt tension by frequency:* Turn on the frequency-finding device. The laser light will turn on. Tap or pluck the free belt span to induce vibration in the belt. Hold the laser probe no more than 25mm off the free belt span, with the laser facing the outside of the belt. Check the frequency being displayed on the frequency-finding device. For new belts the frequency must be 103Hz. For used belts it must be 96Hz.

If no tension measuring tool is available there is another way to have an *indication* of the required belt tension. This method only works when original Blastrac belts are used. There are 2 marks placed at the back side of the motor bracket. Tighten the tension nuts till the motor flange is close to the mark. For the 50Hz configuration use the highest mark and use the lowest mark for 60Hz configuration.

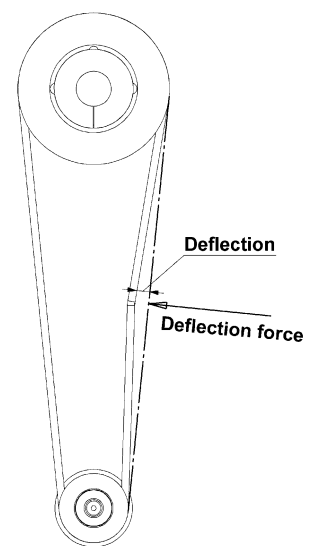
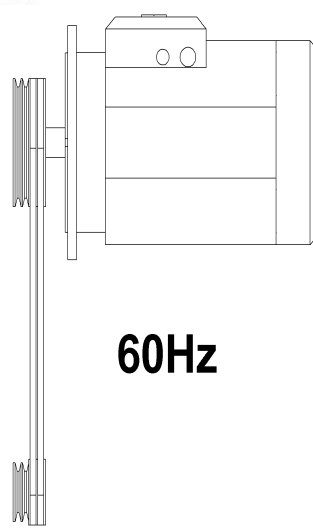
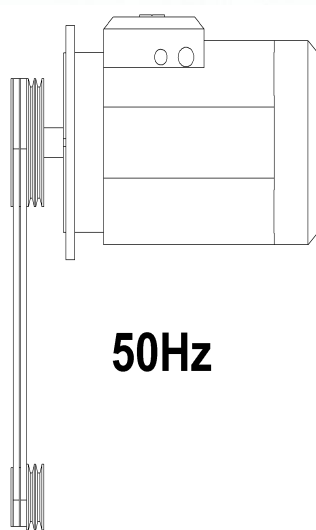



5. Operation

During operating the machine, the following additional safety instructions must be followed closely. Before switching on the machine make sure that no-one can be endangered when the machine starts up. Make sure that no vehicles, such as forklift trucks and other equipment run over the electric cable and the dust hose.

All persons in the proximity of the machine must wear safety glasses with lateral protection as well as safety shoes and ear protection. The operator is obliged to wear close-fitting protective clothing and a dust mask.

5.1 Before switch on

- Check if the distance from magnet to the floor is 8 – 10 mm. Check this height with aluminium strips.
- Check the distance from brush sealing to the floor. This may be max. 1 mm.
- Fill the separator equally with the selected abrasive up to the bottom of the separator tray. The abrasive valve must be closed whilst doing this.
- Connect the blast machine and dust collector with the dust hose. This connection must be reliable.
- Connect the power supply cable of the dust collector with the main power supply / generator. Be sure that the electrical power supply is correct.

5.2 Checking the turning direction of the motor(s)

- Start the machine for a few seconds by pressing the green 'Blastmotor ON' button.
- Stop the machine by pressing the red 'Blastmotor OFF' button.
- Check the rotating direction of the Blastmotor (indicated with an arrow).

Correcting the turning direction of the motor(s)

- Switch off all motors and put the main power switch to the OFF-position
- Wait for a complete standstill of all drives.
- Take the plug out of the power source.
- Change the phases.
- Check the turning direction of the motor again.

When blast cleaning concrete the abrasive magnetic valves may only be opened when the blast cleaning machine is travelling! If the machine is at a standstill and the valves are open deep holes may be blasted into the concrete surface within seconds.

5.3 Switching the machine on

- Before switching on the blast machine, switch the dust collector on. The dustcollector is needed to vacuum off all the created dust and helps to cool the blast machine.
- Press the green push button "Blastwheel ON" and check the rotating direction of the blastmotor. The correct direction is given with an arrow on the housing of the motor. If the blastmotor turns the wrong way, correct this immediately.
- Select the speed using the speed control knob on the steering handle.
- When the machine is traveling pull the abrasive control lever towards you to open the magnetic valves. Observe the ammeters. They may indicate the full load amperage. After having blasted aprox. 2 m, close the abrasive valves, stop the machine and check the blasted surface.
- If the 'hotspots' is too much on the right, turn the cage a little bit clockwise.

Never adjust the cages during blasting!

When the blast head is lifted from the floor, abrasive escapes from the sides of the blast head at high speed! If the machine is moved with the blast head raised, the abrasive magnetic valves must be closed!

Alter the direction only after closing the magnetic valves!

5.4 Operation

Carry out blasting in parallel tracks in such way that the dust hose and electric cable do not become twisted. The next figure shows the recommended blast cleaning paths leading away from the dust collector.

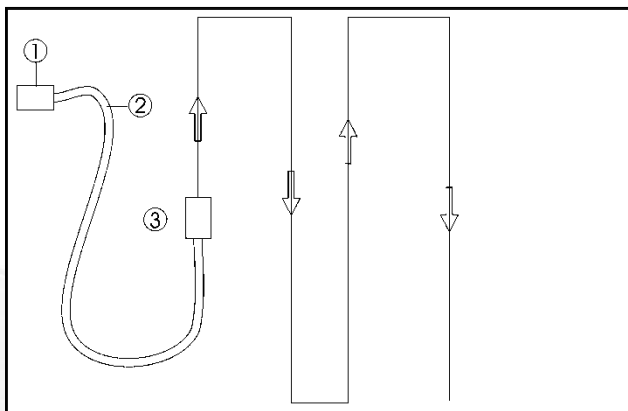

1	Dust collector
2	Dust hose and electric cable
3	Blast cleaning machine

Make sure that no vehicles, such as forklift trucks and other equipment run over the electric cable and the dust hose.

The selection of the correct advancing speed of the blast machine is important for a good blast cleaning result. In the case that the surface has different characteristics (e.g. different hardness or different coating thicknesses), a uniform blast result can be achieved by varying the advancing speed during blast cleaning.

The advancing speed depends on the material of the surface to be treated and the desired profiling.

The correct advancing speed can be found out by observing the blasted surface and varying the speed during the blast cleaning process.

Slight profiling on concrete requires a higher speed than coarse profiling (6 - 10).

Blasting on steel requires a very low advancing speed (0 - 2).

Check the separator tray every 3 hours for foreign matter and large contaminants.

5.5 Switching off the machine

- Close the abrasive valves.
- Press the red button "Blast motor OFF"
- Switch the main switch to position "OFF"
- Pull out the connector of the main power supply of the machine.
- Switch off the filter unit.
- Wait for standstill of all drives before any inspection or maintenance works are started.



5.6 The blast pattern

Abrasive leaving the blast wheel blades is not thrown in all directions. Scatter is restricted to an angle of about 50°. This is achieved through the use of the control cages which surround the impellers. The position of the window in the control cages determines the blast patterns.

Correct adjustment of the control cages and thus of the blast patterns is the most important factor for optimum working with the blast cleaning machine.

Incorrect adjustment of the control cages results in very high wear and premature blasting-through of the liners in the blast wheel housing, as well as reduced blasting performance, uneven cleaning and a possible loss of the rebound energy of the abrasive.

The following 5 factors affect the blast pattern:

- The turning direction of the blast wheel must correspond to the instructions on the housing (arrow indicating the turning direction).
- With increased wear of the tune-up kit (impeller, control cage) the blast patterns will change.
- The size of the abrasive affects the blast pattern. With every exchange of abrasive, the blast patterns must be re-adjusted.
- The correct adjustment of the control cages is the most important factor to obtain an optimum blast pattern. Each control cage has a lateral window. The position of the window determines where the abrasive is fed onto the blast wheel blades and where it hits the surface to be treated.
- Different types and hardness of surfaces.

5.7 Adjusting the blast patterns

- a) Move the blast head of the blast machine onto a 5-8 mm thick steel plate and blast for 45 seconds at full amperage without moving the machine from the spot.
- b) Move the machine from the blast zone and carefully inspect the steel plate.
- c) You will find the hot spots on the blasted surface where the machine has developed the highest blast cleaning intensity. This spot is normally somewhat lighter than the rest of the blast cleaned area due to the large amount of heat that is generated.
- d) If the 'hotspot' is too much on the right, turn the control cage a little bit clockwise. Remove the feed spout (5) and loosen the cage clamps (3+4) for cage adjusting, the control cage has cast grooves (1+2) which indicate the opening/window of the cage.
If the 'hotspot' is too much on the left, turn the cage a little bit counter-clockwise.
After adjustment, tighten the cage clamps (3+4) and place the feed spout (5) back.
- e) Now the blasting procedure can be started. When a concrete surface is to be blasted, check the blast pattern again after some meters and re-adjust slightly if necessary.

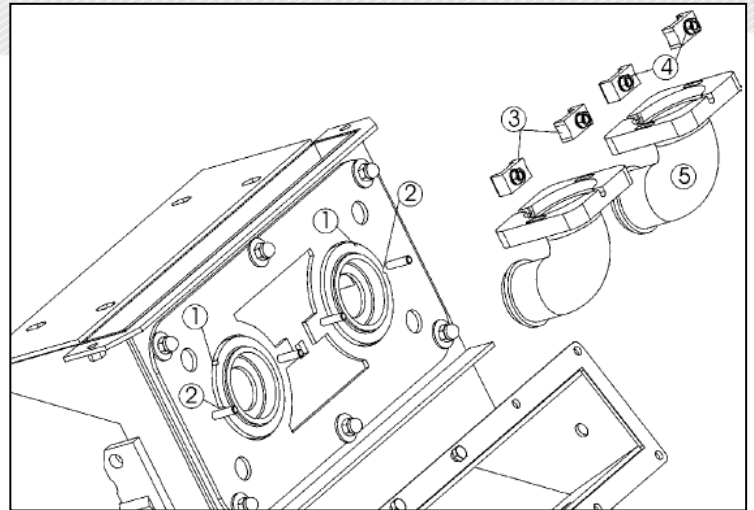
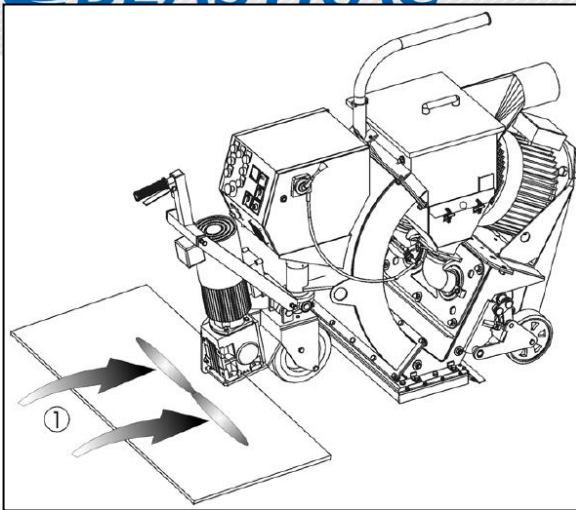

WARNING! Never loosen the cage clamps lever or try to adjust the blast wheel cover when the machine is in operation!!

6. Maintenance

Pay attention to Chapter 3 "Safety" during maintenance and repair works.

Failures due to inadequate or incorrect maintenance may generate very **high repair costs** and long standstill periods of the machine. **Regular** maintenance therefore is imperative.

Operational safety and service life of the machine depends, among other things, on proper maintenance.

The following table shows recommendations about time, inspection and maintenance for the normal use of the machine.

Operating hours/ time period	Inspection points, maintenance instructions
12 h after repairing	Check all accessible screw connections for tight seat.
Every 3 hour	Check the separator tray, the hopper, the feed spouts and blast wheels unit for foreign matter and large contaminants.
Daily and prior to starting work	Check that all safety devices working adequate. Check the feed spouts, magnet- and brush sealing. Check the blastwheels, control cages and liners. Check the electric connections for sediments of dirt or foreign bodies. Check the electric motors for dirt and other contaminants. Check all safety devices working adequate. Check the function of the residual current operated device. Check the hose connections for tightness and fixed seat. Check all hoses on the machine for damages or leakage. Make sure that the dust bin is emptied
Every 3 months	Check the tension of the V-belts Clean the chain drive of the drive unit and check the tension.
Annually	Full overhaul and cleaning of the complete machine.

The time indications are based on uninterrupted operation. When the indicated number of working hours is not achieved during the corresponding period, the period can be extended. However a full overhaul must be carried out at least once a year. This technical inspection shall be carried out by the manufacturer or an instructed person.



Due to different working conditions it can't be foreseen how frequently inspections for wear check's, inspection, maintenance and repair works ought to be carried out. Prepare a suitable inspection schedule considering your own working conditions and experience.

Pay attention to unusual noises or strong vibrations. Check for the cause of every big change. Call a technician if you have doubts about the cause or when a repair without a technician seems not possible without damages. Only use genuine Blastrac spare parts.

After use, clean the machine with the dust collector, so there is no dust on the machine. See to it that any wastes or fibre residues do not remain in the machine.

Our specialists will be happy to assist you with more advice.

Follow additional operating and maintenance of Original Equipment Manufacturers if included during your service and maintenance work.

Prior to any repair works on the machine and its drives, secure the machine against unintentional switching on. Put the machine to its safety off position.

The machine is in a safe condition when it cannot generate any hazard.

Further is advised:

Clean the machine every day with air and non-aggressive materials. Never use a high pressure water cleaner to clean the machine.

Store the cleaned and dry machine in a dry and humid free room. Protect the electrical motors from moisture, heat, dust and shocks. Remove the abrasive out of the abrasive storage hopper.

All repair work must to be done by qualified Blastrac personnel, this to guarantee a safe and reliable machine.

Any guarantee on the machine is expired when:

- Non original Blastrac parts have been used
- Repair work is not done by qualified Blastrac personnel
- Changes, add on's or conversions are undertaken without written permission of Blastrac BV

Screws, bolts etc. that have been removed must be replaced with those of the same quality, strength, material and design.

Do not weld, flame cut or perform grinding works on or near the machine. Danger of fire or explosion exists! Provide adequate ventilation when working in a confined space. Secure the maintenance area if necessary.

6.1 Changing the tune-up kit

The tune-up kit consists of one blastwheel (10), one control cage (15) and a central fixing bolt.

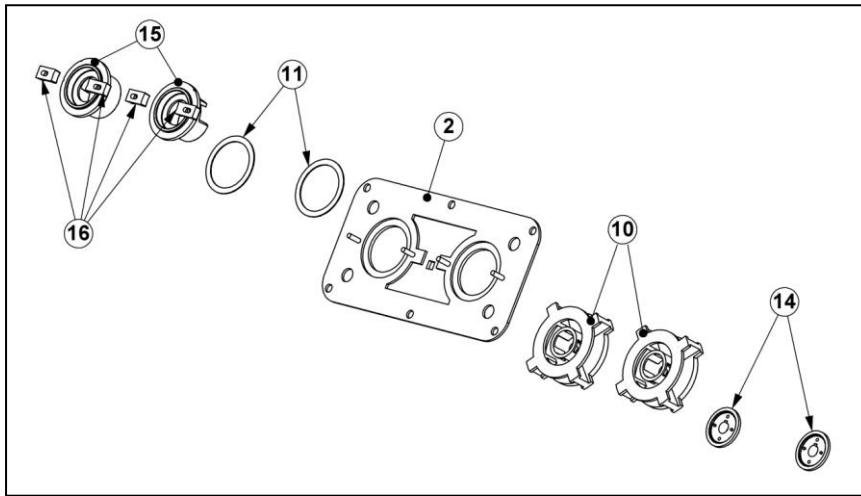

- Remove the feed spouts by loosening the star nuts and pulling them out of the housing.
- Remove the cage clamps (16) and remove the control cages (15) and control cage shims (11).

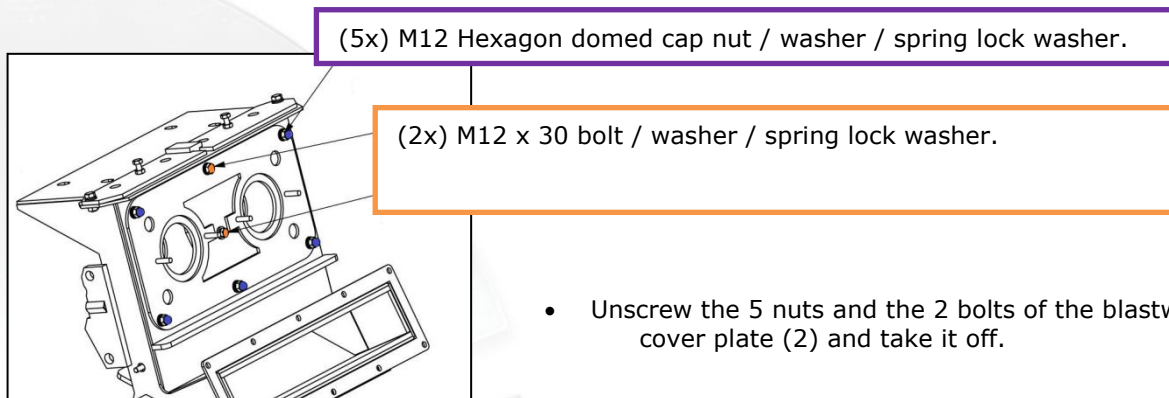

- Unscrew the 5 nuts and the 2 bolts of the blastwheel cover plate (2) and take it off.

New blastwheel coverplates have 4 welded nuts which will make it easier to remove the coverplate without damages.

Use 2 M10 bolts and screw them in the welded nuts until the blastwheel coverplate is released from the blasthousing.

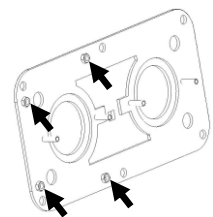

- Block the blastwheel (10) and remove the central fixing bolt.
- Take the blastwheel(10) out of the housing and check the hub (14) for wear.

Use a new central fixing bolt when mounting a new blastwheel!

- Place the blastwheels(10) on the hubs (14) and tighten the central fixing bolts.
- Fix the blastwheel cover plate (2) with 5 nuts and 2 bolts and place the control cage shims (11).
- Insert the control cage (15) in the **center** and clamp the cage with the cage clamps (16) so that the blastwheel (10) can rotate freely. Make sure the cast grooves are positioned correctly.
- Turn the blastwheel(10) manually. It must rotate freely.
- Place the feed spouts back between the abrasive valve and the cage (15).

6.2 Changing the liners

12	Centerliner bottom part
13	Center liner top part
20	Side liner LH
21	Side liner RH
22	Top liner
23	Plenum top liner
25	Plenum bottom liner
26	Plenum bottom side liner

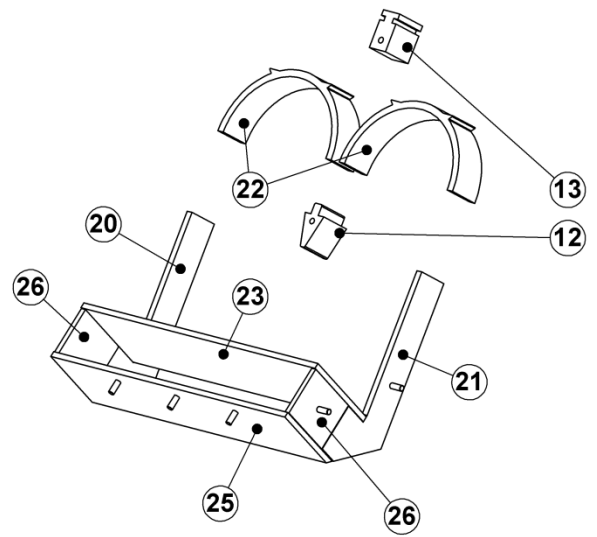

- Remove the blast wheel cover plate, by unscrewing the 5 nuts and 2 bolts.
- Loosen the press bolts (1) of the top liner. Loosen the bolts(2) of the blast housing cover(3) and remove it.
- Loosen the bolt of the center liner top part(13), at the back of the blasthousing and remove it.
- Loosen the bolt of the center liner bottom part(12), at the back of the blasthousing and remove it.
- Remove top liners(4)
- Loosen the nuts(6) of the left and right side liner(7). Take them out at the bottom of the housing.
- Loosen the nuts(8) of the left and right plenum bottom side liners(9). Take them out at the bottom of the housing.
- Loosen the nuts(10) of the top and bottom plenum liners(11). Take them out at the bottom of the housing.

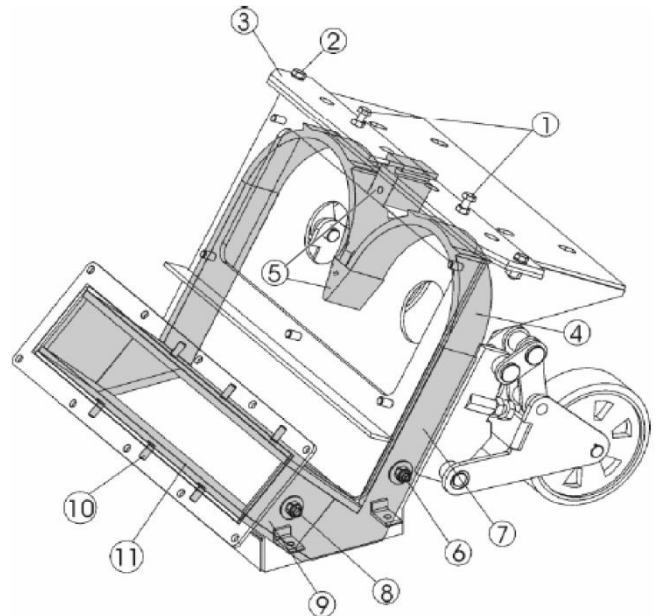

To mount the liners, keep on the following sequence:

Prior to mounting the liners, check all threads for contaminants and clean them if necessary.

- First place all the plenum liners (23 + 25 + 26) and fix them with the nuts.
- Place the side liners(20 + 21) inside the housing. The sideliners may stick out the body for max. 1mm. Tighten the nuts.

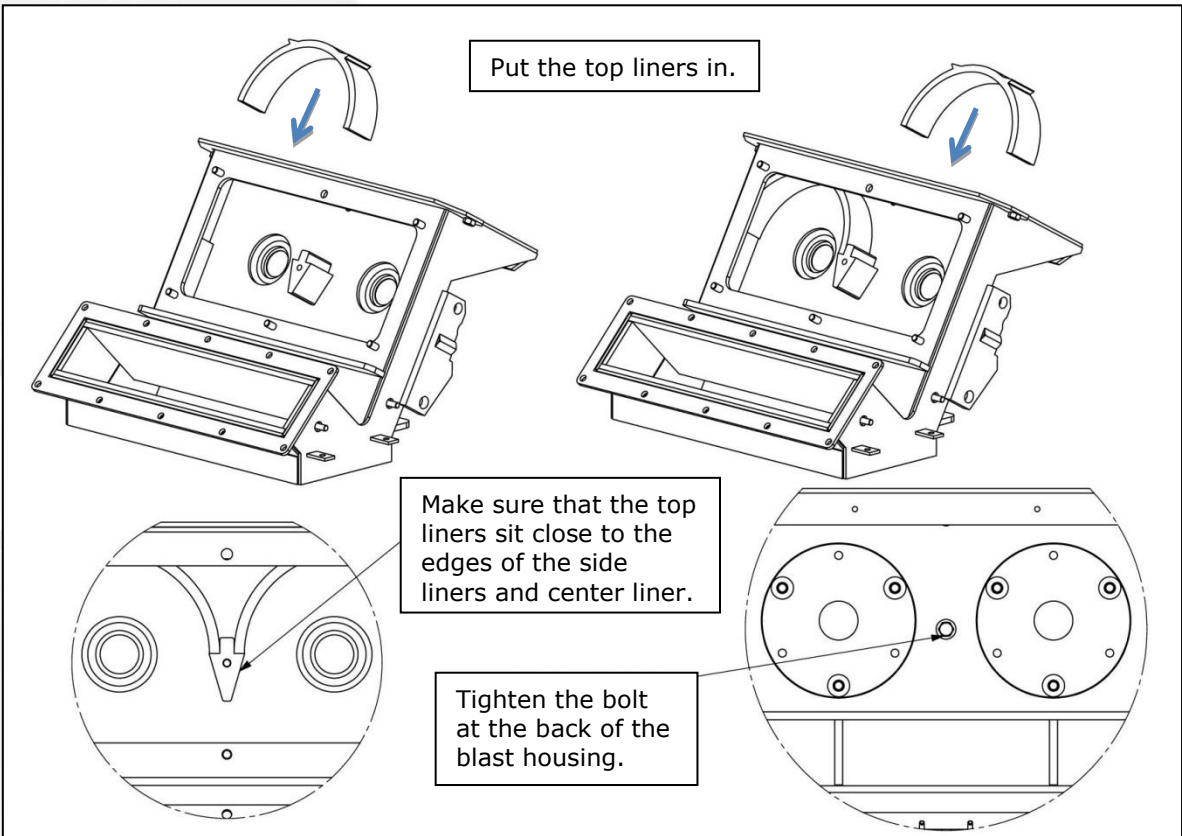
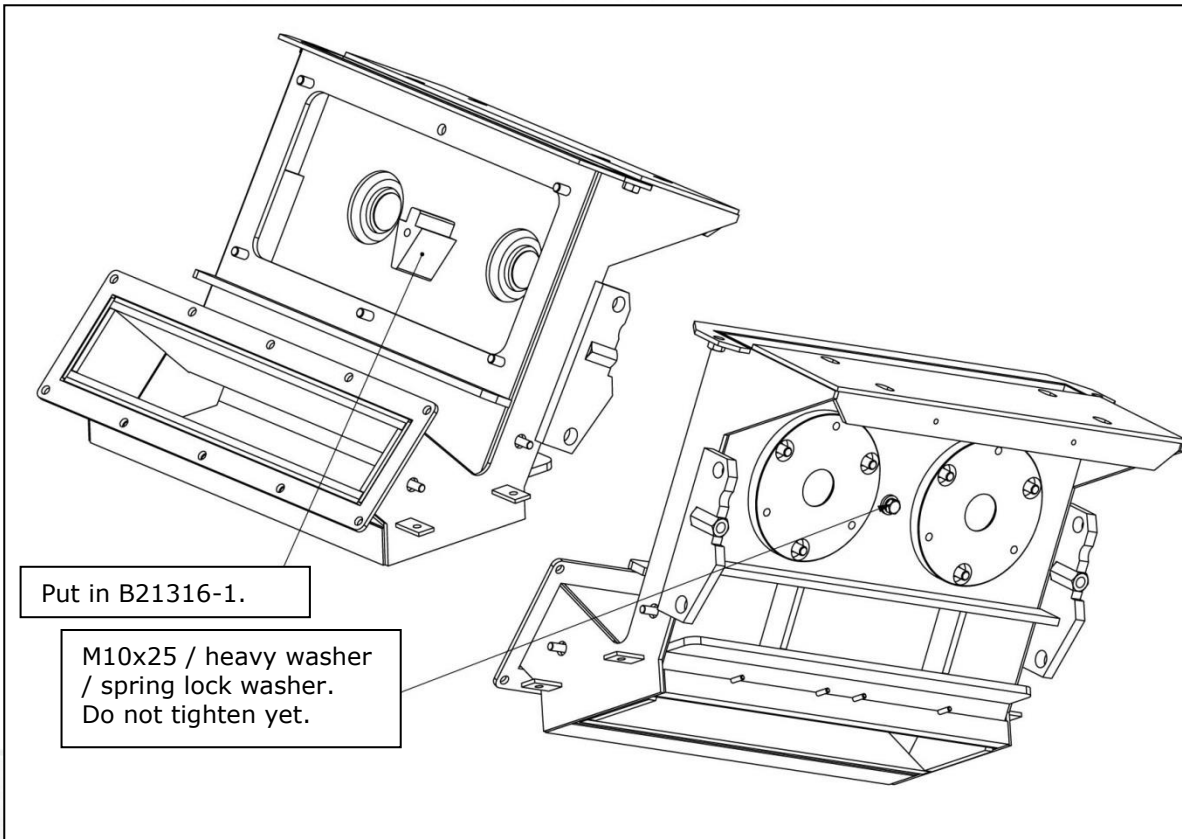

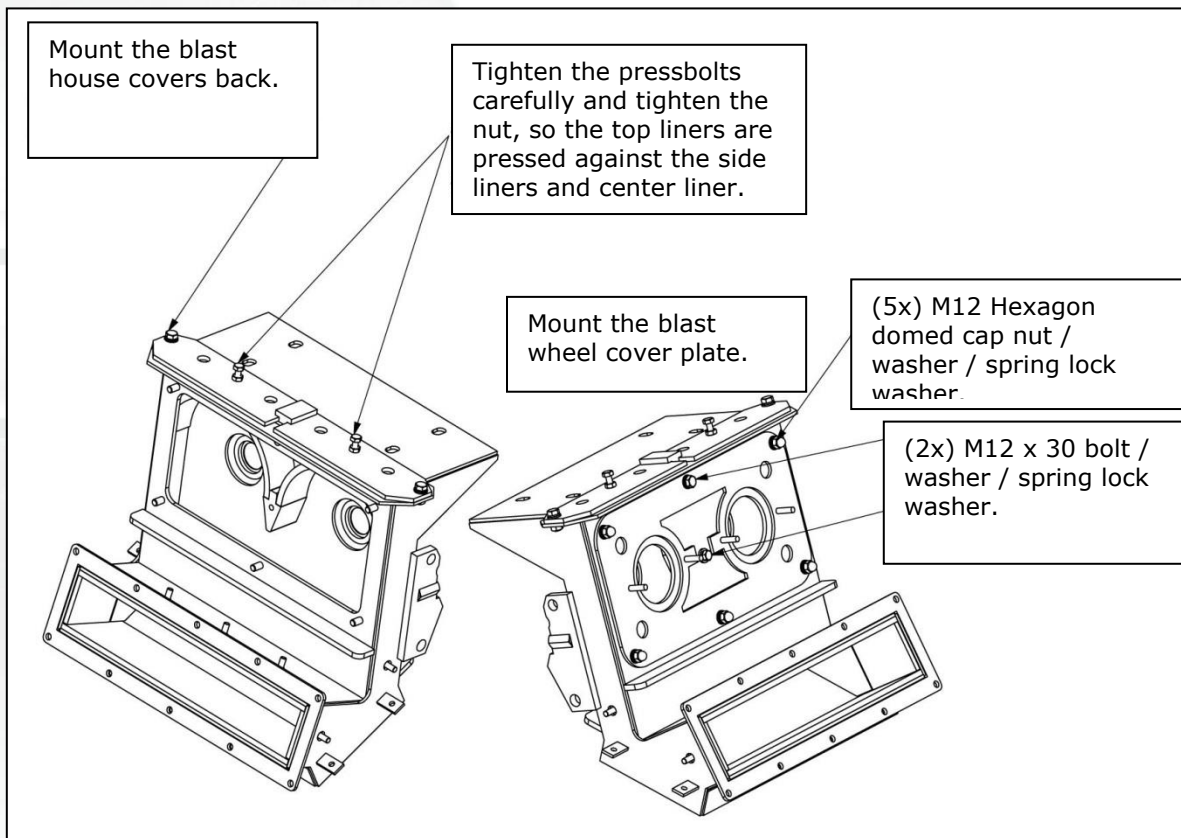
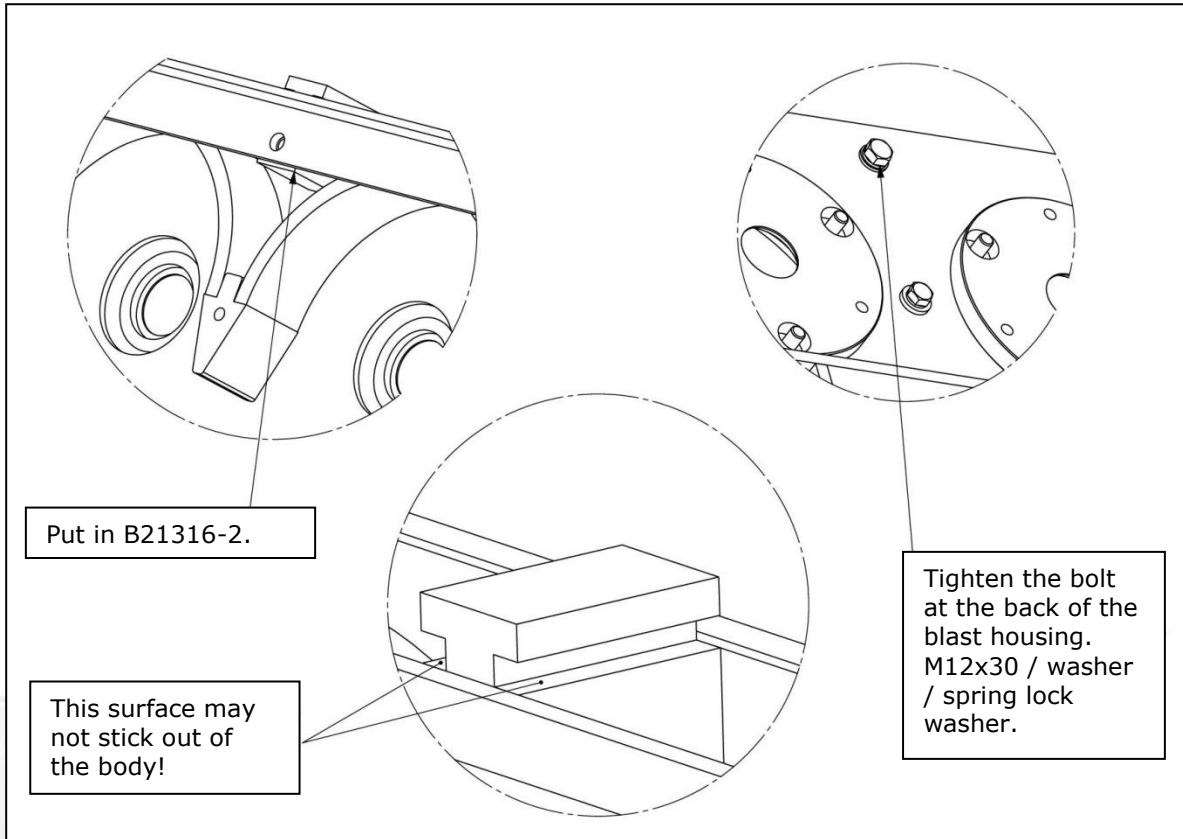

6.3 The V-belts

The V-belt drives are designed for the installed driving power. To force a higher output through an excessive high tension of the V-belts will result in broken belts, damage to the bearings and causes loss of the total efficiency. Too low belt tension will cause slipping with the result of a very high temperature of the V-belt and a premature destruction of it. Temperatures over 70° for a longer period will decrease the working life and the efficiency of the V-belts. The grooves of the V-belt pulleys must be free of rust, fat and dirt and must not show any damages. The use of belt wax or similar substances in order to increase the friction coefficient is not necessary and it damages the V-belts. Soiling due to oil, grease or chemicals have to be avoided.

In order to get perfect power transmission the V-belt drives have to be checked every 3 months.

6.4 V-belt mounting

Remove the belt guard only when the driving motor is in standstill and the power supply cable of the machine is disconnected from the power source.

- Reduce the distance between the driving motor and the bearing to release the tension of the V-belt drive.
- Carefully put the V-belts in the grooves of the V-belt pulley by hand and without using the force.
- Increase the distance between the driving motor and the bearing to stretch the V-belt as following described.
- Fix the required driving gear guards.

6.5 V-belt tension

The correct V-belt tension is of utmost importance in order to obtain a perfect power transmission and to reach the usual working life of the V-belt. Too low or too high tension causes frequently a premature breakdown of the V-belt. Excessive belt tension results in damaged bearings at drives.

Check the tension of the V-belt by pressing the thumb on the belt. The belt has the correct tension if you can press it in about 10-15 mm at approx. 10 kg. pressure.

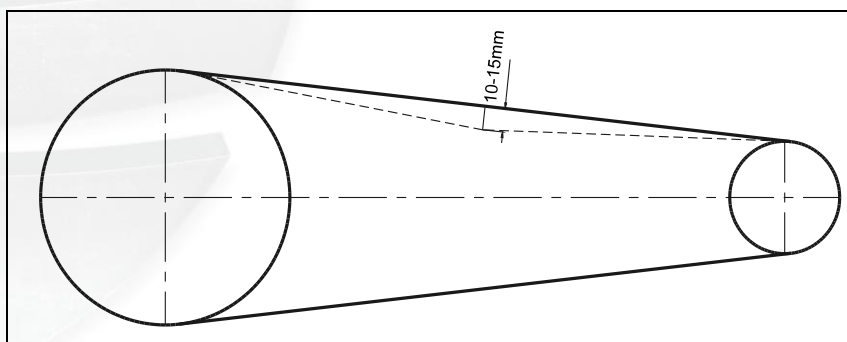



6.6 The chain drive

A chain drive needs relatively little maintenance when the correct chain is selected, when it is mounted correctly and, in this case of application, is not lubricated. The drive chain is protected by a chain guard. The chain guard prevents excessive contamination and prevents accidents.

The chain drive should be cleaned every three months. On these occasions check the aligning of the chain wheels and the chain tension.

Cleaning

In order to clean thoroughly first remove the dirt adhering to the outside of the chain drive using a hard or wire brush. Then wash the chain in petroleum ether or similar. After that clean the dirt from the internal parts of the chain.

Alignment of the chain wheels

Check the mounting precision by means of a ruler to be put to the chain wheels.

Incorrect mounting makes the internal link plates press against the external link plates and, thus, accelerates the chain wear or even causes the chain wheels to lock up.

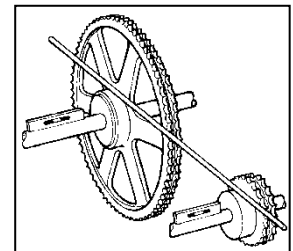

Chain tension

The travel drive motor is mounted on a receiver plate with slotted holes. When it is necessary to re-tense the chain, this can be carried out by shifting the motor in the slotted holes (1). The correct chain tension is achieved when the chain allows to be pressed for about 5 mm between the chain wheels.

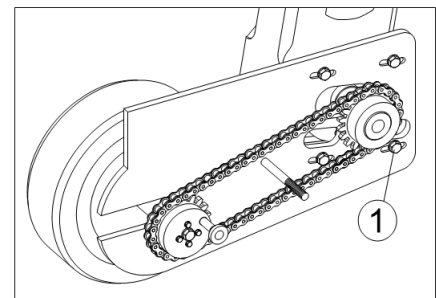

Fitting the chain

Before mounting the chain it must be degreased to prevent any abrasive or abrasive particles from adhering.

The chain is supplied as a chain string and has to be prepared during mounting. This is done as follows: Place the chain on the chain wheels so that the links lie in tow adjacent gaps between the teeth. Now close the chain using the coupling link. With heavy chains or big distances between the shafts use a pre-stressing tool in order to bring the two end links so close together that the coupling link can be inserted without being deformed.

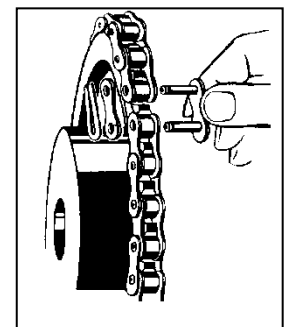

On mounting coupling links with springs, their closed sides should point to the running direction of the chain (see figure). Put the spring onto the link plate and press it over the pin into the ring groove by means of a pair of tongs. Demount the spring in the opposite order.

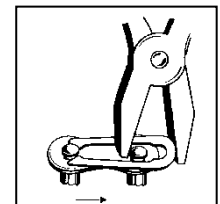

Re-lubrication of the traction wheel bearings

The bearing units of the traction wheel are equipped with a grease fitting which allows the bearings to be re-lubricated in service. Re-lubricating the bearings once every 2 years should be more than sufficient.

When lubricating, care must be taken to use greases that are compatible with the original grease. We suggest a medium temperature, lithium calcium base, NLGI Grade No. 2 grease having an oil with a viscosity of 200mm²/s at 40°C. When a unit is being re-lubricated, avoid excessive pressure which may cause damage to the bearing seals.



7. Selection of abrasive

The Blastrac blast cleaning machines are designed and built to operate with **Blastrac abrasive**.

Blastrac abrasive has a very high quality and has the rebounding ability required for the efficient use of the machine. The selection of abrasive is very important since this is the material to carry out the surface treatment.

Media nr. 2

Is often used when the surface is only subsequently sealed.

- creates fine profiles, e.g. on vacuum concrete and non-glazed tiles
- removes thin layers of rust on steel surfaces
- removes thin layers of paint

Media nr. 3 Abrasive S330

- creates a fine to medium texture on concrete.
- removes glazing from tiles prior to subsequently coating with antiskid floor sealings
- removes old impregnations and coatings about 1 mm thick

Media nr. 4 Abrasive S390

Standard abrasive, suitable for about 50-60 % of all applications. Creates a medium profile on concrete. Fulfills the same purpose as Media No. 3 when a higher speed of the machine is required, e.g. on asphalt, in order to keep the thermal load low.

- removes laitance from new concrete
- roughening of smooth concrete or natural stone
- removes coatings with a thickness of 1-3 mm
- cleaning of steel surfaces

Media nr. 5 Abrasive S460

This media is used to create a coarse profile or to increase the work speed in the case of surfaces hard to treat.

- removes sediments on concrete prior to coating
- removes thick paint coatings or rust from steel surfaces, bridges, tanks, etc.
- removes flexible coatings on parking house decks
- removes road markings and retexturing of asphalt and concrete roads

Media nr. 8 Abrasive SG25

Only as an addition to Media No. 3, No. 4 and No. 5 with maximum 30% content.

Media No. 8 should never be used without blending since otherwise the wear in the machine as a whole would increase disproportionately.

- removes polyurethane coatings
- removes adhesive remnants
- removes rubber deposits
- penetrates coatings hard to remove
- also suitable to be used on steel for extraordinary roughness

Please take into account that the use of incorrect abrasive increases wear.

Our service engineers have the experience to select the appropriate abrasive for the individual cases of application.

Please consult your local **Blastrac** customer service department if you have any questions about the selection of the best abrasive for your blast cleaning work.

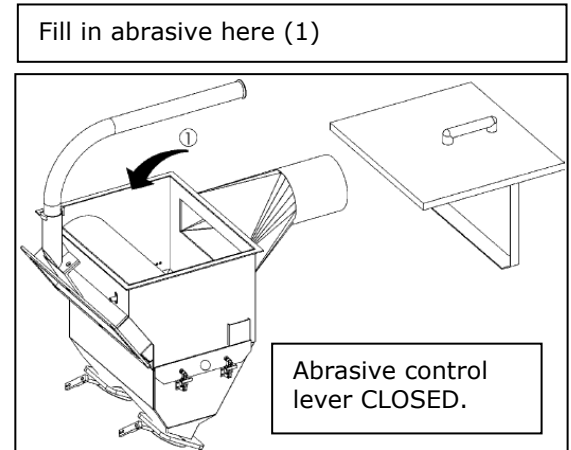

8. Troubleshooting

Fault	Possible cause	Remedy
Excessive vibration	Blast wheel is worn irregularly. Imbalance due to worn or broken wheel blades.	Replacing the tune-up kit. Replace the tune-up kit and remove all broken parts from the machine.
Unusual noise	Too little play or poor alignment of the rotating parts. Loose and incorrect set screws. Squeaking wheels. Seizing motor.	Check alignment of the rotating parts (blast wheel and control cage). Check whether all screws and parts are fixed tightly). Replace the wheels. Replace the motor.
Reduced or no blasting performance	Inadequate abrasive supply to the blast wheel. Contaminated abrasive. Feeding of abrasive - magnetic valve and abrasive storage hopper. Blast wheel or control cage. Adjustment of the magnetic valve. "Shocked blast wheel". At the start of the blast process too much abrasive at once hits the wheel. The travel speed is too high.	Clean wire mesh, top up abrasive if necessary. Abrasive is heavily contaminated, check the dust collection system. Check and clean blocked feed spout or magnetic valve. Worn blast wheel or control cage, replace tune-up kit if necessary. Check the adjustment of the magnetic valve. Close the magnetic valve and stop the blast wheel motor. Start the blast process again and slowly open the valve. Reduce the travel speed.
Escaping abrasive	Poor sealing.	Check all seals and replace if necessary.
Abrasive loss on the surface or escaping abrasive at the blast head	Incorrect height adjustment of the magnetic seals. Worn magnetic and/or brush seals. Poor abrasive quality. Worn tune-up kit.	Adjust the magnetic seals. Replace the magnetic and/or brush seals. Contact Blastrac . Replace the tune-up kit.



Contaminated abrasive	<p>The dust collector is not generating enough suction power so that dust remains in the abrasive.</p> <p>Clogged dust hose</p> <p>Ripped or damaged dust hose</p>	<p>Check the dust collector (filter-cartridges, dust hopper and seals)</p> <p>Check and clean the dust hose</p> <p>Replace dust hose</p>
Excessive wear in blast housing and rebound plenum	<p>Wrong abrasive.</p> <p>Incorrect setting of the control cage</p>	<p>Contact Blastrac.</p> <p>The thrown abrasive blasts the housing and not the surface to be blasted. Adjust the blast pattern.</p>
Machine is not moving	<p>The travel speed is too low.</p> <p>Blast head gets caught on the floor.</p> <p>Drive unit broken / not connected</p>	<p>Increase the travel speed.</p> <p>Shut the machine down and adjust the height.</p> <p>Check chain drive.</p>
Blast wheel motor does not switch on	<p>Motor protection switch has triggered.</p>	<p>Check and switch on again. Check the mains power supply.</p>
Blast wheel motor switches off during operation	<p>Safety fuse or fault current breaker has triggered.</p> <p>Connection cable is defective.</p> <p>Cables connecting the units (travel motor, etc.) are defective.</p> <p>Motor protection switches have triggered.</p>	<p>Have the fault checked by an electrician.</p> <p>Replace the cable.</p> <p>Replace the cable(s).</p> <p>Have the fault checked by an electrician.</p>
Machine does not travel	<p>Fuse defective, short circuit in the travel motor lead or tachometer lead, motor defective.</p> <p>Control unit defective.</p> <p>Potentiometer defective.</p>	<p>Have the unit checked by an electrician.</p> <p>Replace the control unit.</p> <p>Replace the potentiometer.</p>

Note: If the motor protection switches of the blast wheel motors have been triggered by overload, they can be switched on again after a short cooling down period.

9. Technical data

	2-20DT
Power consumption blast motor	22KW
Electrical connection (voltage is given on the control box)	400V / 50Hz 400V / 60Hz
Blast width	550 mm
Drive speed	0 – 33 m/min
Length	1950 mm
Width	720 mm
Height	1400 mm
Weight	630 kg
Noise level (under load)	83dB(A)
Vibration level	1.9 m/s ² Allows 13,9 hrs. of working with the mentioned equipment without having to use anti vibration precaution measures.
Dust hose connection	Ø150 mm

The electrical diagrams of the electrical system are placed inside of the control panel.
Design and specifications are subject to change without notice by Blastrac BV.

IMPORTANT NOTES:

The indicated measurements refer to new machines, the declared vibration and noise emission levels represent the main applications of the machine. However, if the machine is used for different applications, with different abrasives or poor maintenance, the vibration and noise emissions may differ. This may significantly increase the exposure level over the total working period.

A precise estimation of the level of exposure to vibration and noise should also take in account the times when the machine is switched off or even running, but not actually in use. This may significantly decrease the exposure level over the total working period.

Identify additional safety measures to protect the operator from the effects of vibration and noise such as: proper and regular maintenance of the machine and the accessories, keeping the hands warm, organization of work patterns for example by using rotation schedules. The use of anti-vibration gloves could also decrease the effects of the vibrations transmitted. Always use ear protection when working with this machine.

Old equipment contains valuable materials which are valuable for re-processing. **The machine parts must not be thrown away in the normal household waste**, but should be disposed of at a suitable proper collection system, e. g. via your communal disposal location. This way the materials can be re-used in an environmentally responsible manner.

Despite the fact that this guide is made with care, Blastrac takes no liability for errors in the manual and the possible consequences. We are naturally very interested in your findings and additions. No part of this publication may be reproduced and / or published in print, photocopy, or other form without prior permission by Blastrac.

The original Operating Instructions are in the English language. Any other language is a translation of the original version.



BLASTRAC EUROPE

WE'RE READY TO ASSIST YOU!

BLASTRAC THE NETHERLANDS

EUROPEAN HEAD OFFICE
Utrechthaven 12
NL - 3433 PN Nieuwegein
Tel.: +31 (0)30 601 88 66
Fax: +31 (0)30 601 83 33
Email: info@blastrac.nl
WWW.BLASTRAC.EU

BLASTRAC POLAND

SALES & SERVICE CENTRE
Golina, ul. Dworcowa 47E
63-200 Jarocin
Tel.: +48 (0)62 740-41-50
Fax: +48(0)62 740-41-51
Email: info@blastrac.pl
WWW.BLASTRAC.PL

BLASTRAC FRANCE

SALES & SERVICE CENTRE
ZI - 29, Av. des Temps Modernes
F - 86360 Chasseneuil du Poitou
Tel.: +33 (0)5 49 00 49 20
Fax: +33 (0)5 49 00 49 21
Email: info@blastrac.fr
WWW.BLASTRAC.FR

BLASTRAC ITALY

SALES & SERVICE CENTRE
S.S. 10 Padana Inferiore, 41
IT - 29012 Caorso (PC)
Tel.: +39 0523 814241
Fax: +39 0523 814245
Email: info@blastrac.it
WWW.BLASTRAC.IT

BLASTRAC GERMANY

SALES & SERVICE CENTRE
Richard-Byrd-Str. 15
50829 Köln
Tel.: +49 (0) 221 709032-0
Fax: +49 (0) 221 709032-22
Email: info@blastrac.de
WWW.BLASTRAC.DE

BLASTRAC UKRAINE

SALES & SERVICE CENTRE
Nezalezhnosti 14, of. 21
07400 Brovary
Tel.: +38 (0)44 222 51 28
Fax: +38 (0)44 277 98 29
Email: info@blastrac.com.ua
WWW.BLASTRAC.COM.UA

BLASTRAC SPAIN

SALES & SERVICE CENTRE
Calle del Estío, 9
E - 28500
Arganda del Rey, Madrid
Tel.: +34 91 660 10 65
Fax: +34 91 672 72 11
Email: info@blastrac.es
WWW.BLASTRAC.ES

BLASTRAC UNITED KINGDOM

SALES & SERVICE CENTRE
Unit 2a, Outgang Lane, Dinnington
Sheffield, South Yorkshire
GB - S25 3QU
Tel.: +44 (0) 1909 / 569 118
Fax: + 44 (0) 1909 / 567 570
Email: info@blastrac.co.uk
WWW.BLASTRAC.CO.UK

BLASTRAC MIDDLE EAST

SALES & SERVICE CENTRE
P.O. box 29424
Dubai / United Arab Emirates
Tel.: +971 4 3245760
Fax: +971 4 3245761
Email: info@blastracdx.ae
WWW.BLASTRAC.AE

BLASTRAC NORDIC

SALES & SERVICE CENTRE
Lekstorps Industriväg 13D,
443 41, Gråbo
Sweden
Tel.: +46 (0) 31 30 333 55
Email: info@blastrac.se
WWW.BLASTRAC.SE

BLASTRAC INDIA

SALES & SERVICE CENTRE
G.B. Warehousing, GAT NO- 523,
Pune- Nagar Road, Wagholi
Pune- 412 207
Tel.: +91 99213 98109
Email: info.blastrac.in
WWW.BLASTRAC.IN